

This bulletin is supplied as technical information only and is not an authorization for repair. No part of this publication may be reproduced, stored in a retrieval system, or transmitted, in any form or by any means, electronic, mechanical, photocopying, or otherwise, without written permission of DaimlerChrysler Corporation.

SUBJECT:

Second Row 40/20/40 Fold & Tumble Seat Mechanism Binding

OVERVIEW:

This bulletin involves adjusting the tumble mechanism on one or both 40% second row seats as necessary.

MODELS:

2006

(XK)

Commander

NOTE: This bulletin applies to vehicles equipped with Second Row 40/20/40 Fold & Tumble Seat (sales code CF1).

SYMPTOM/CONDITION:

One or both second row 40% seats are difficult to unlatch and tumble forward.

DIAGNOSIS:

If the Symptom/Condition is present, perform the Repair Procedure.

REPAIR PROCEDURE:

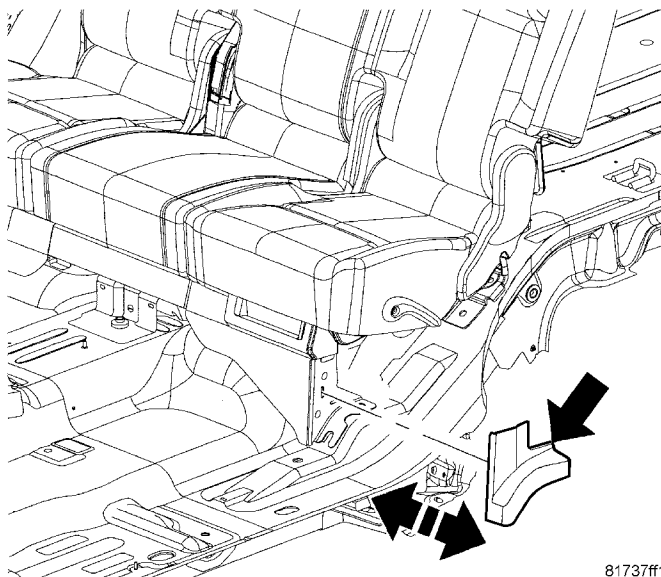

Fig. 1 SEAT SHIELD END CAP

1. Remove the trim cover end cap (Fig. 1).
2. Remove the front tumble mechanism shield (Fig. 2).

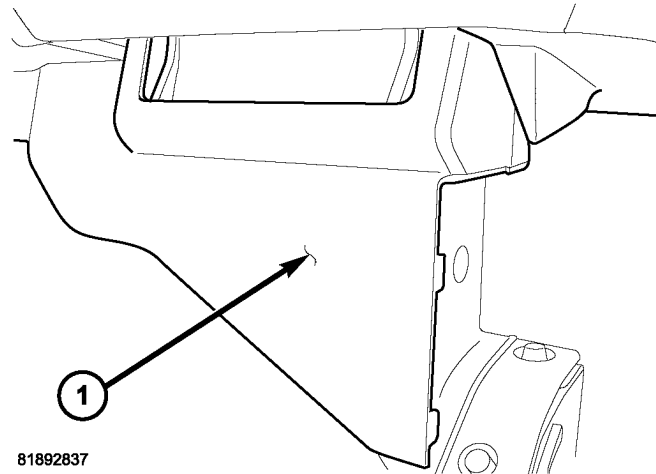

Fig. 2 FRONT TUMBLE MECHANISM SHIELD

1 - FRONT TUMBLE MECHANISM SHIELD

3. Note the position of the two tabs (fore and aft) on the forward seat leg (Fig. 3).
4. Make sure the seat is in the fold flat position with the latches engaged. Loosen the outboard tumble mechanism bolt (Fig. 3).

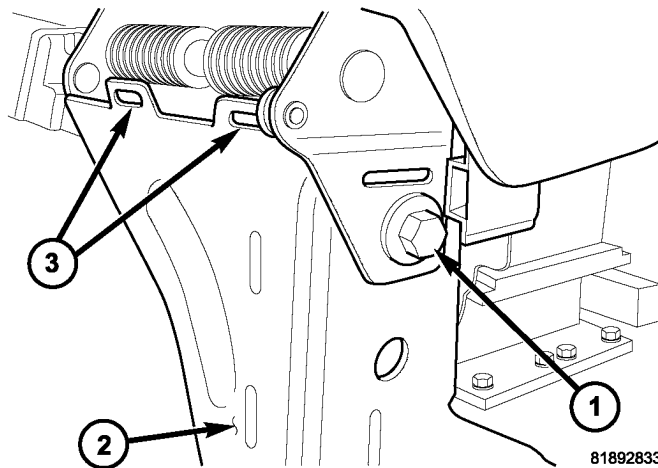

Fig. 3 OUTBOARD TUMBLE MECHANISM BOLT

1 - OUTBOARD TUMBLE MECHANISM BOLT
 2 - FORWARD SEAT LEG
 3 - NOTE TAB POSITIONS

5. Loosen the underside tumble mechanism bolt (Fig. 4)

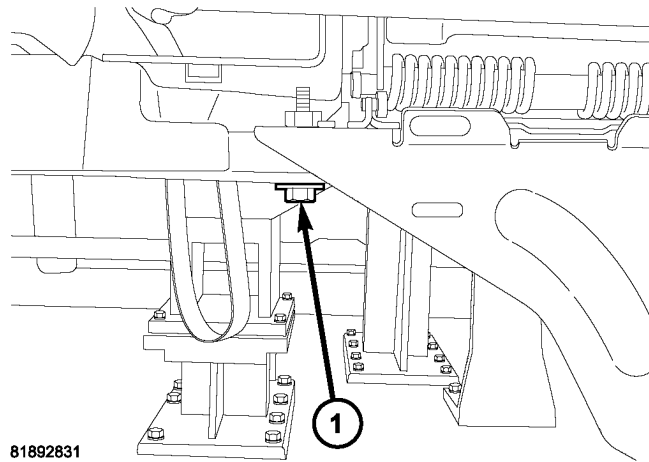

Fig. 4 UNDERSIDE TUMBLE MECHANISM BOLT

1 - UNDERSIDE TUMBLE MECHANISM BOLT

6. Release the seat from the rear latches and move to the tumbled position ([Fig. 5](#)).

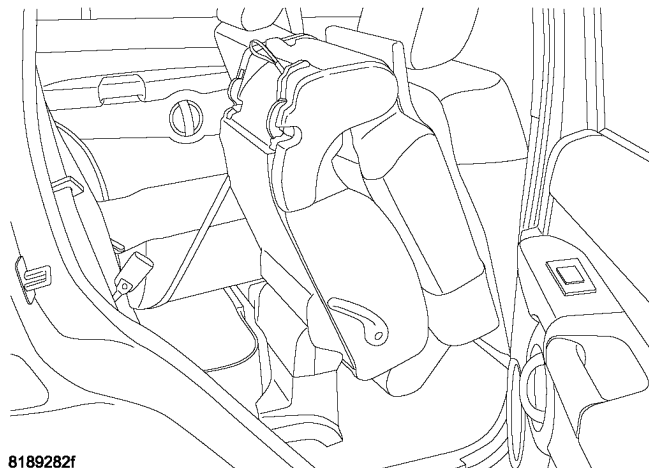

Fig. 5 SEAT IN TUMBLE POSITION

7. Return the seat to its fold flat position by lowering the seat onto the latch strikers. Make certain that both latches fully engage their respective strikers. Without allowing the seat to fully tumble forward, slowly cycle the seat several times from its fold flat and latched position to unlatched to ensure proper alignment. Finish by returning the seat to its fold flat and latched position.
8. Have the tabs on the forward seat leg moved from their original position as illustrated in ([Fig. 3](#))?
 - a. Yes >> go to [Step #9](#).
 - b. No >> Repeat [Step #5](#) through [Step #8](#).
9. Tighten the underside tumble mechanism bolt to 34 N·m (25 ft. lbs.) ([Fig. 4](#)).
10. Tighten the outboard tumble mechanism bolt to 34 N·m (25 ft. lbs.) ([Fig. 3](#)).
11. Verify that the condition no longer exists by cycling the 40% seat. Attempt to tumble the seat from the fold flat position repeatedly.

12. Install the front tumble mechanism shield (Fig. 2).
13. Install the trim cover end cap (Fig. 1).
14. If necessary, repeat Step #1 through Step #13 on the other second row 40% seat.

POLICY:

Reimbursable within the provisions of the warranty.

TIME ALLOWANCE:

Labor Operation No:	Description	Amount
23-41-60-90	Adjust Second Row Tumble Mechanism - One Side	0.3 Hrs.
23-41-60-91	Adjust Second Row Tumble Mechanism - Both Sides	0.6 Hrs.

FAILURE CODE:

ZZ	Service Action
----	----------------